

**THE
GENERAL
KNOWLEDGE
OF
IDIOTS**

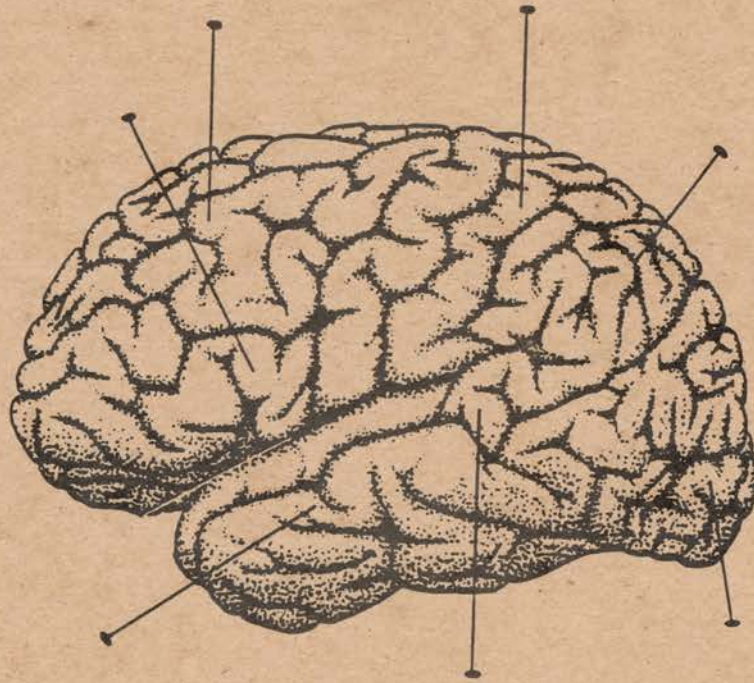

W. Mark Sutherland

Knots



DO



CAN



HAVE



WILL



SHOULD



HAS



WOULD



IS



FORGET
ME



FORGIVE
ME



THOU
SHALT



OR



TO



FROM

Permanent Capitalism Is...

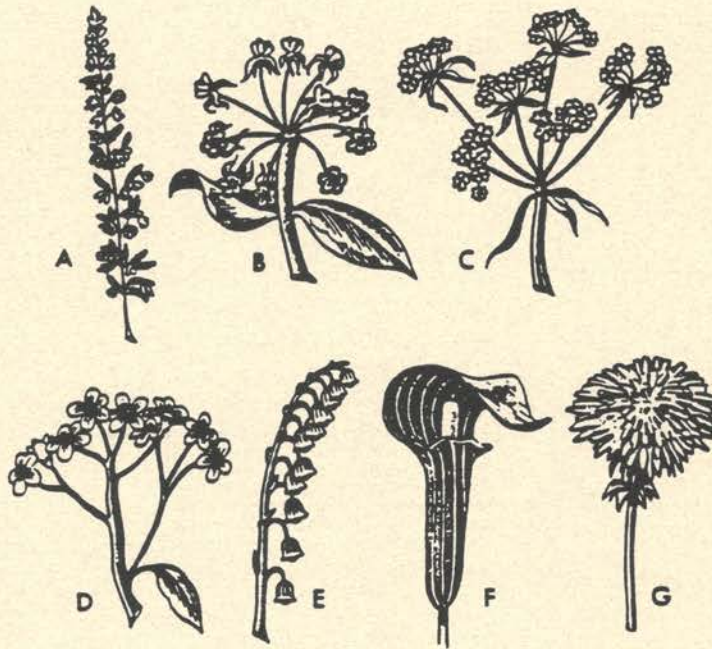

A = CATEGORICALLY GENERAL

B = DIVISION OF LABOUR

C = GENERIC SPECIFIC

D = ABSOLUTE SPECIFIC

E = CONTRADICTIONARY CONDITION

F = FACTORY MODEL

G = TRADE MARK

The Pictorial Tongue

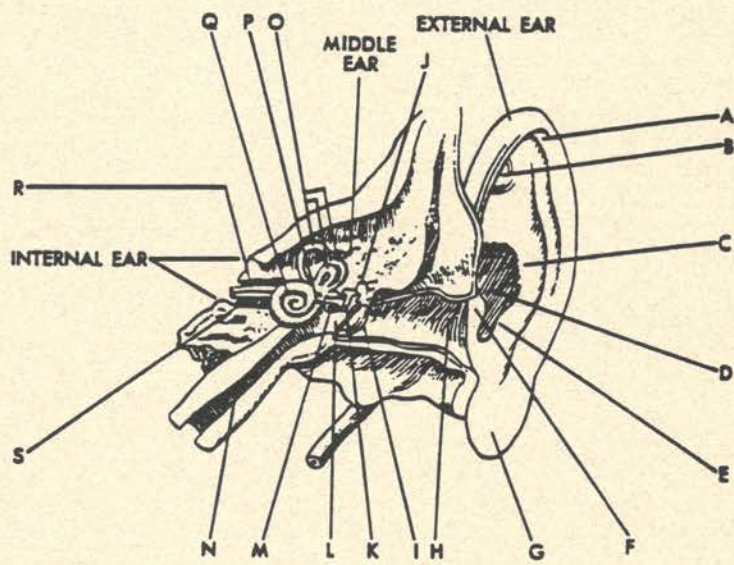

Parallelism

1

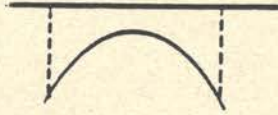

2

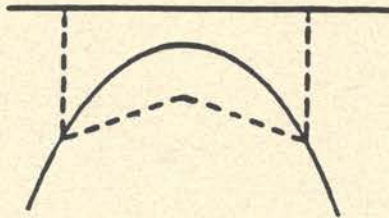

3

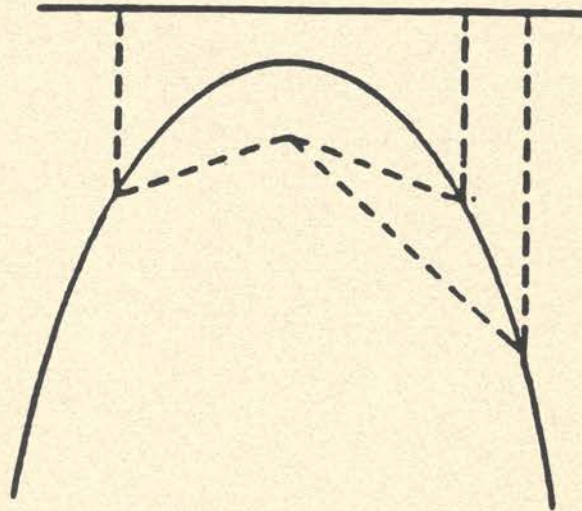

- 1 Tip of John Cage's Thumb
- 2 End of William S. Burroughs Penis
- 3 Toe of Marcel Duchamp's Shoe

The Language of Images

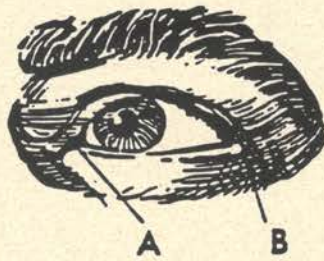
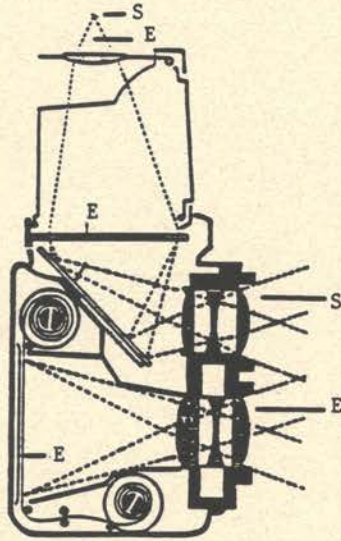

A, Reflex camera (twin-lens)
B, Film

Sea

The Colour of The Blues

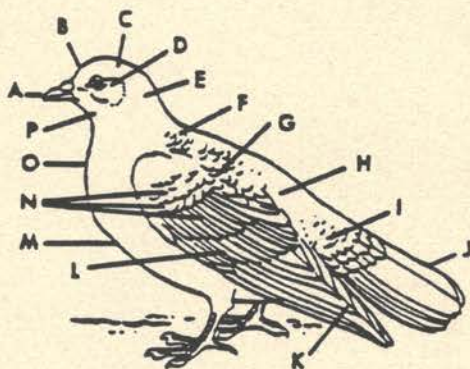

MATHEMATICS



The Empty Skin of History

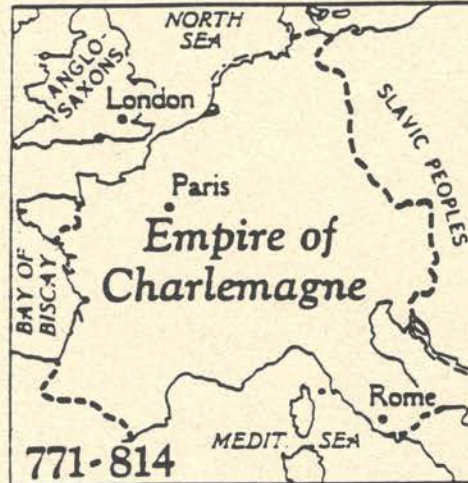

**World War I,
World War II,
World War III,**

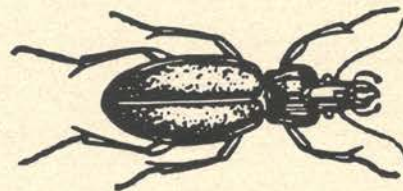

Future History

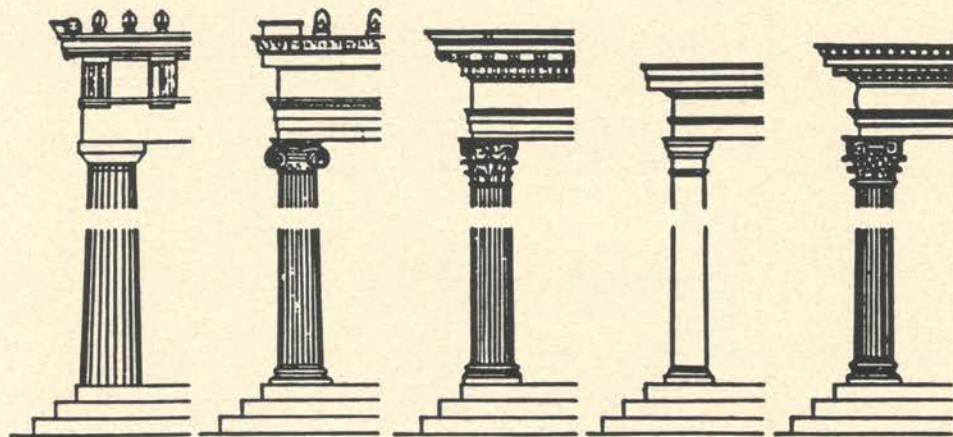

HISTORY
SLEEP

SLEEPS
IS

IN
A

THE
FUTURE

FUTURE
HISTORY

HISTORY
THE

IS
FUTURE

A
SLEEPS

FUTURE
WITH

SLEEP
HISTORY

A Brief History of Mathematics and Language

1

2

3

4

5

6

7

8

9

T

E

N

Obsolete Geography

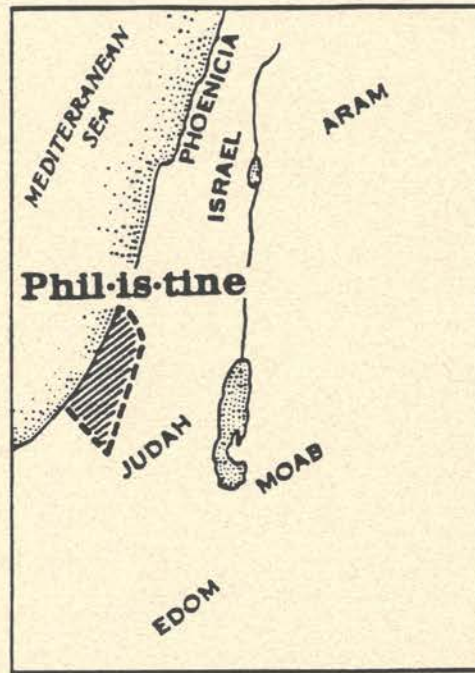

Why Duchamp?



C

Sophism

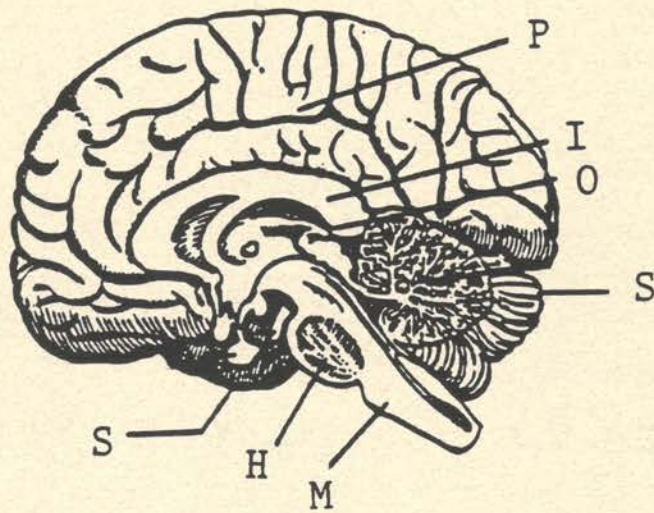

S olipsistic
O risons
P neumatology
H agiology
I nfralapsarianism
S esquipedalism
M etaphrast

Economic and Political Structures

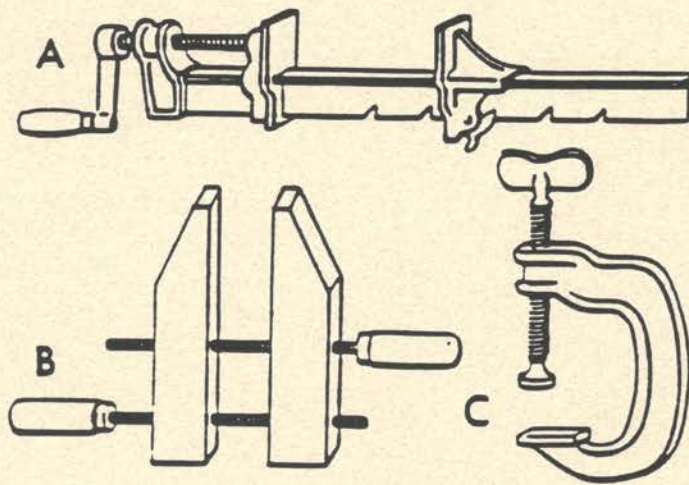

- A - COMMUNISM
- B - CAPITALISM
- C - TOTALITARIANISM

Speak (spek)

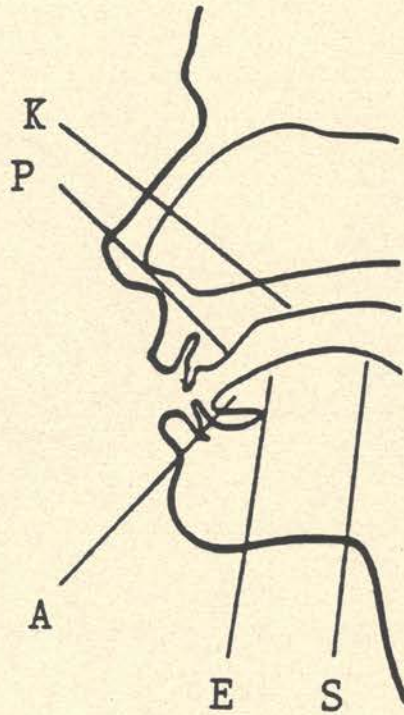

S olipsistic (sol'ip siz'tic)
P hylogeny (fi loj' e ne)
E thnarchy (eth'nâr ke)
A utochthon (ô tok'then)
K aryokinesis (kar'e o ki ne'sis)

Einstein's Brain Before and After Science

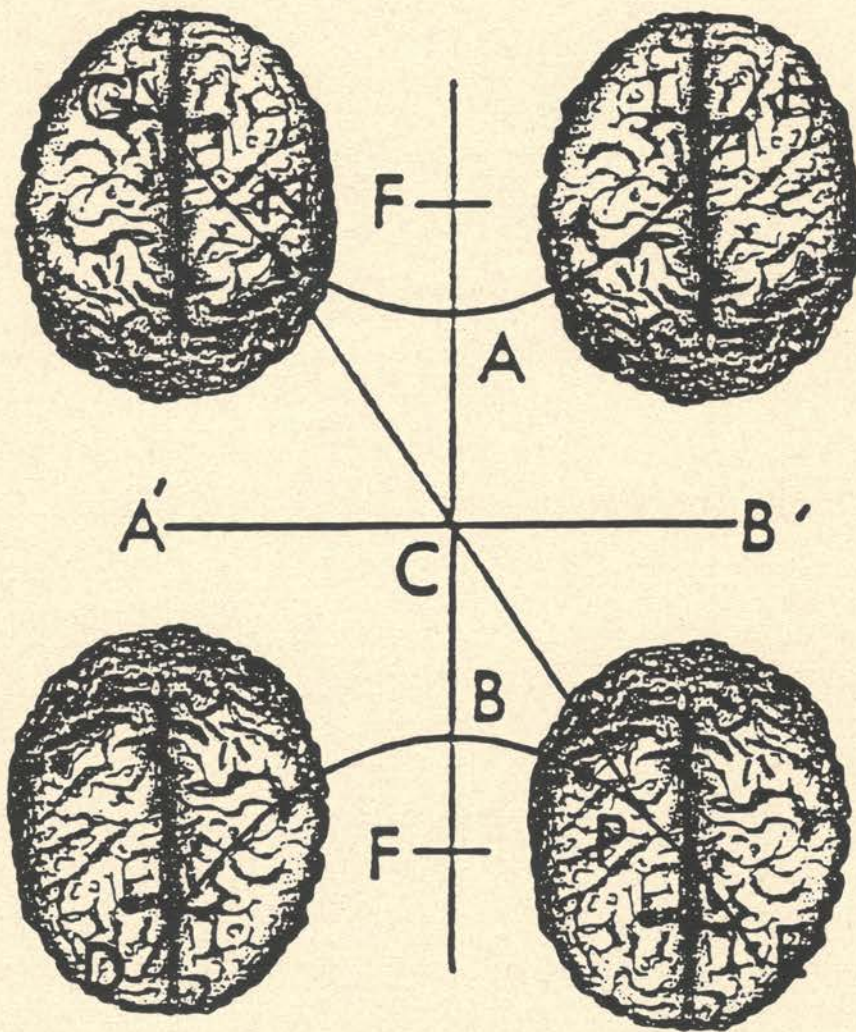

A Brief History of Mathematics and Language

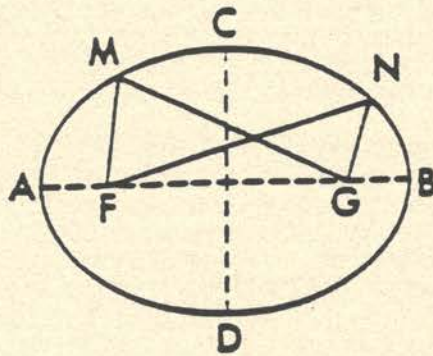

- F = pubescent ranting
- G = grunting pornography
- D = wild generalizations
- B = philosophy
- N = volatile aesthetic
- A = art
- C = precise vision
- M = theology

A Brief History of Modern Art

PART I

a quantity, expressed as $a^2 = a$
3. a quantity that is the second
square of two. 7. *Slang.* a person
interested in current fads, ideas
the square, *Informal.* straight

square or rectangular form or
put in one or more squares or
measuring devices for deviation from
or plane surface. 12. *Math.* a
quantity) by itself; raise to
be or find a square that is equal
circle. 13. to bring to the form
s. 14. to even the score of (in
holders and back) in an erect
similar to a right angle. 16
verb: *Square the cloth on the table*

PART II

rek'tə), n. a pl.
rek'tə), adj.
[] + -AL¹] —re
gle (rek'tāng'g
les. [$<$ ML *re-*
triangle (neut. o
le) = *recti-* REC
gu·lar (rek'tā
ke a rectangle.
the form of a
3. having on
g a right angle
LE + -AR¹] -
n. —rec-tan'g
gular coor'd
hich the axes are
k'tī), n. pl. of
a learned borrower

Music

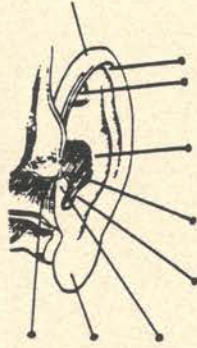

SYMBOLS

All The Wor(l)d Is A Noun



POLITICS



MONEY



FOOD



MUSIC

The Tongue's Spine

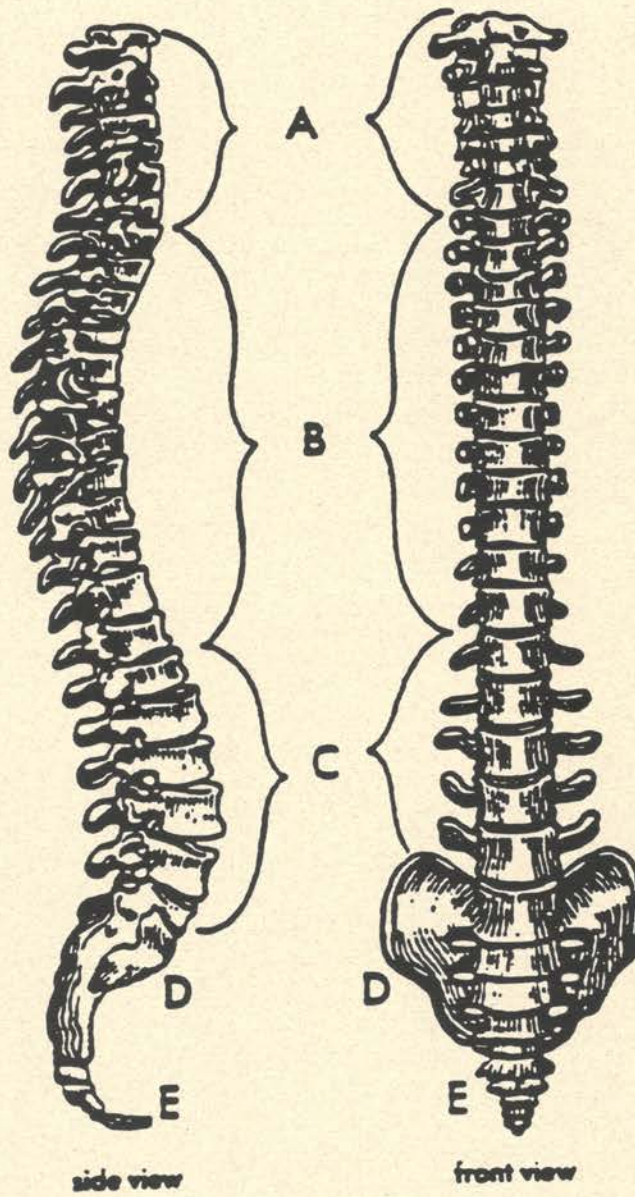

Einstein's Brain Before Science

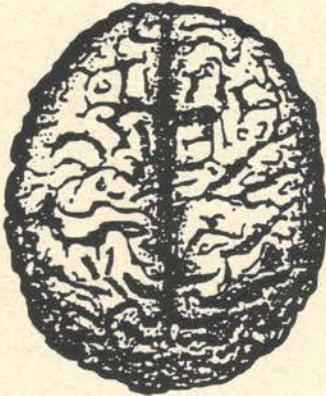

HUMAN BRAIN

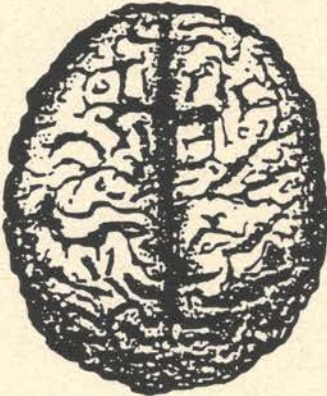

WALNUT

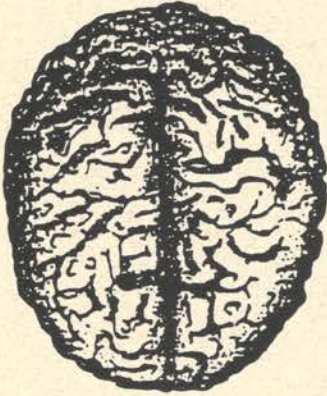

RAISIN

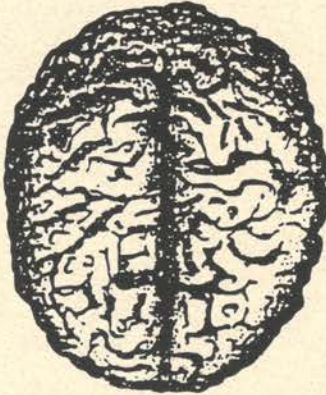

TESTICLE

Informational Architecture

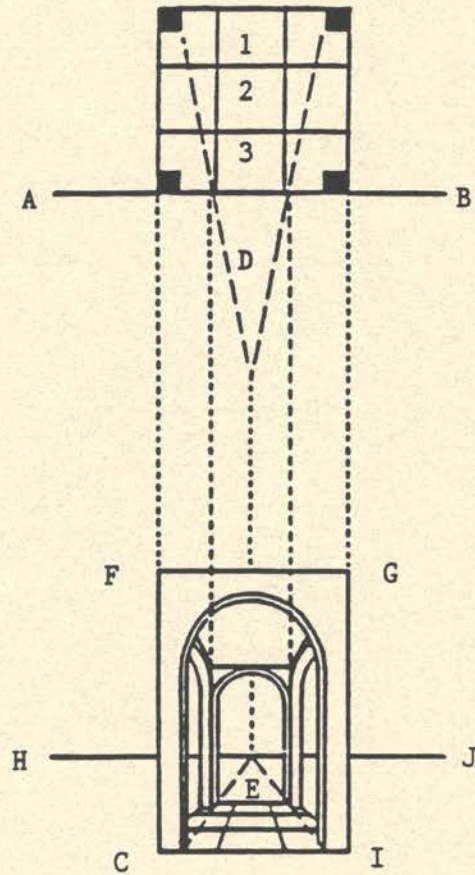

- A - the locus
- B - of my
- C - house
- D - envelopes
- E - space
- F - and
- G - sets
- H - the limits
- I - of my
- J - gaze

Dead Beat

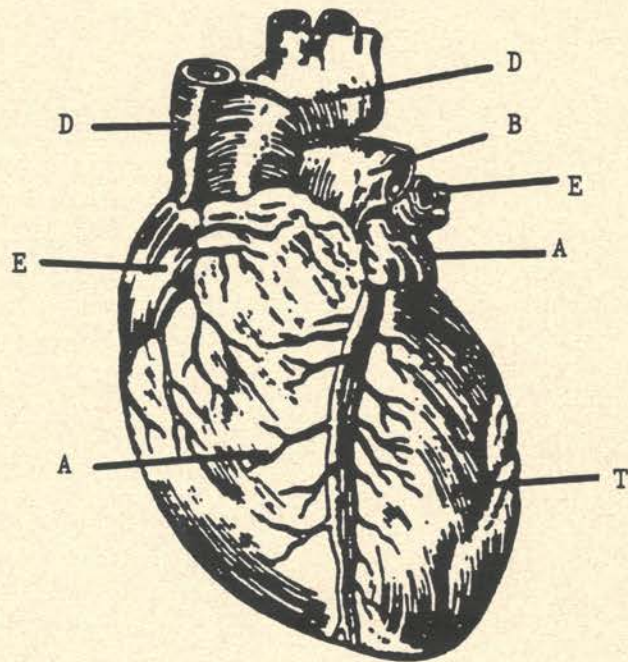

- D - the parted mouth
- E - the wild hair
- A - the hands
- D - the body

- B - no longer
- E - jump
- A - with
- T - desire

Alphabet Skeleton

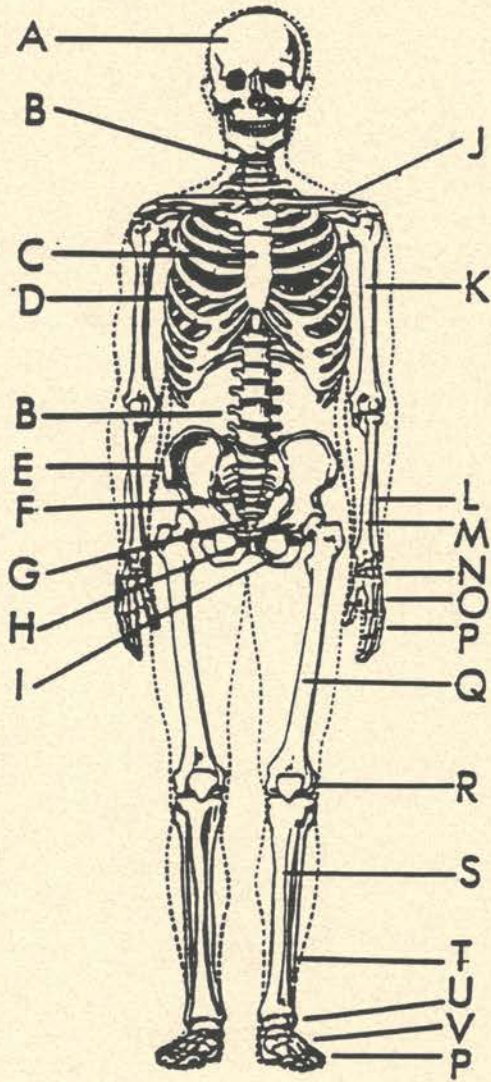

MAN IS ALL MOUTH

3 Normal White Males and Their Phallic Symbols

FREUD
PENIS
MOUTH
SALIVA
DALI
EAR
SCULPTURE
EIGHT
BRONZE
CANCER
SCIENCE
SQUARE
AIR
SPIT
RAZOR
SUN
BRAIN
SHOES
MUSEUM
BEGINNING



JUNG
VAGINA
TONGUE
BLOOD
VERLAINE
HAIR
SPINE
HEART
CONTINENT
THERAPY
ALFONSO
TRIANGLE
WATER
PISS
KNIFE
MOON
BONE
PANTS
LIBRARY
MIDDLE



REICH
ANUS
EYE
SPERM
QUAD
NAILS
SIX
LUNGS
LEFT
AIDS
ART
CIRCLE
FIRE
SHIT
GUN
STARS
TEETH
TIE
GALLERY
END



Late Capitalism Is...

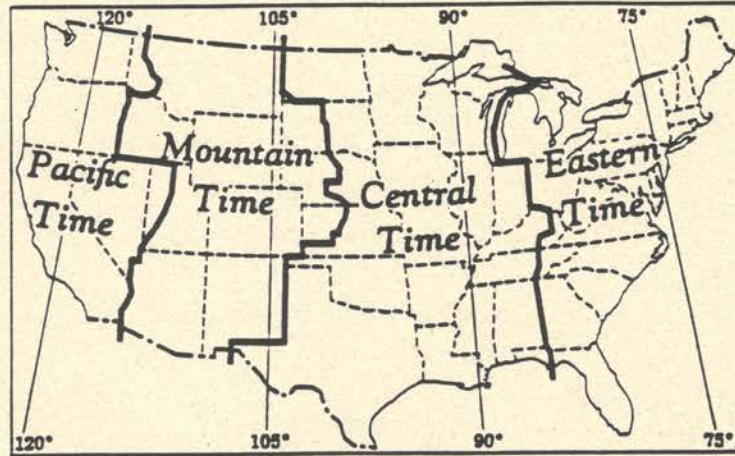

MONEY

1 2 3

A Complete Verb, An Optical System, A Comfortable Object

HEAR

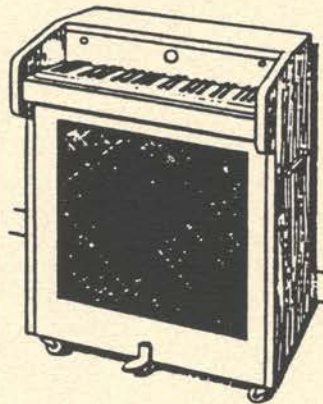

Each Generation Is A Decaying Copy of The Original

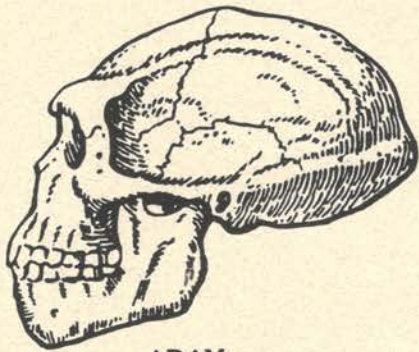

ADAM

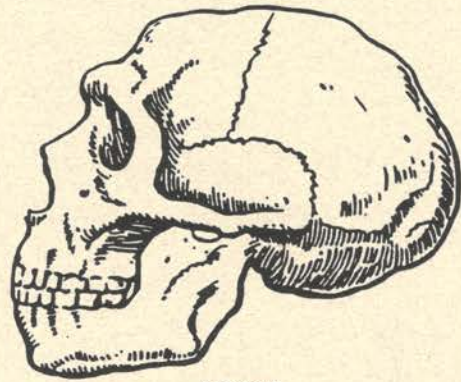

ADAM

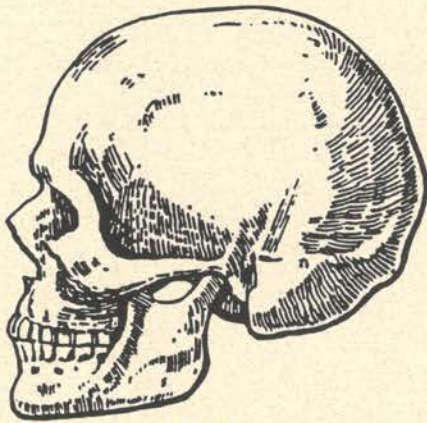

ADAM

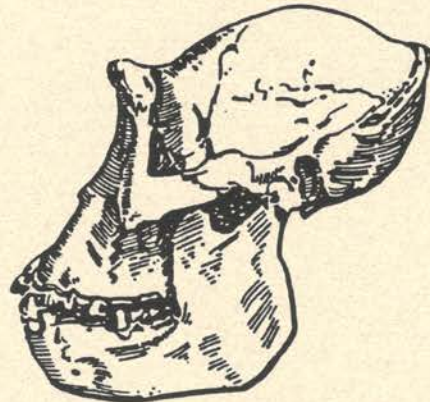

ADAM

Aesthetic Weapons or Systems of Fear

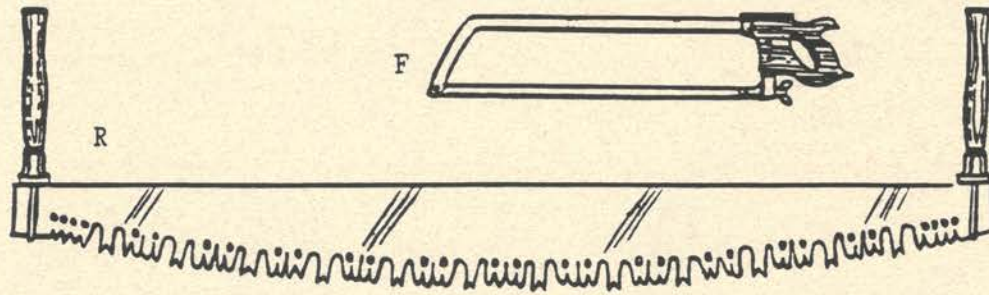

F = THEATRE

E = ART

A = MUSIC

R = POETRY

Each Generation Is A Decaying Copy of The Original

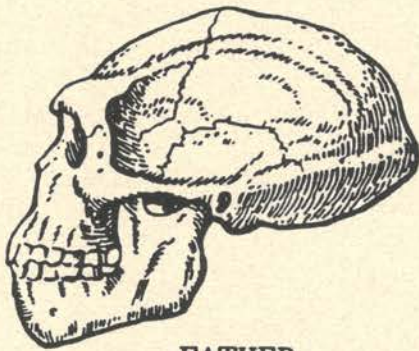

FATHER

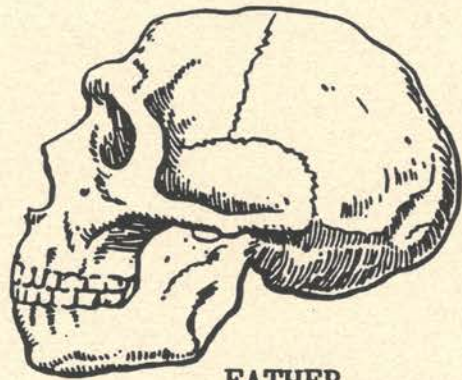

FATHER

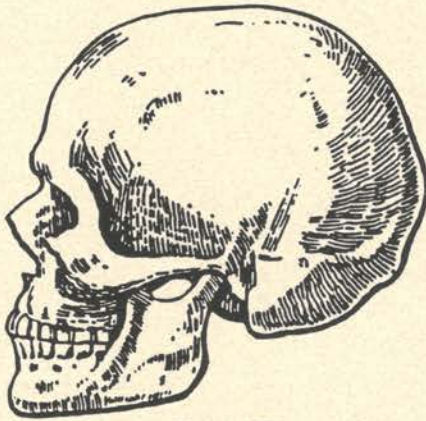

FATHER

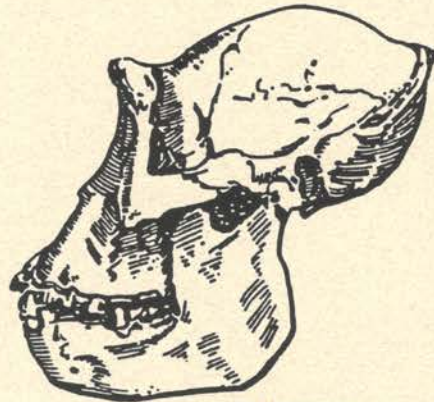

FATHER

Geography is A Noun



POLITICS

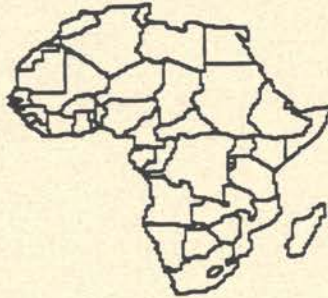

ART



FOOD

Each Generation Is A Decaying Copy of The Original

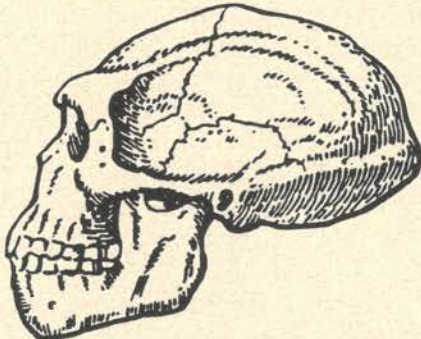

DARWIN

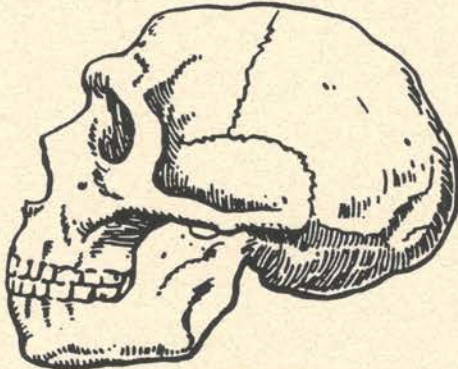

DARWIN

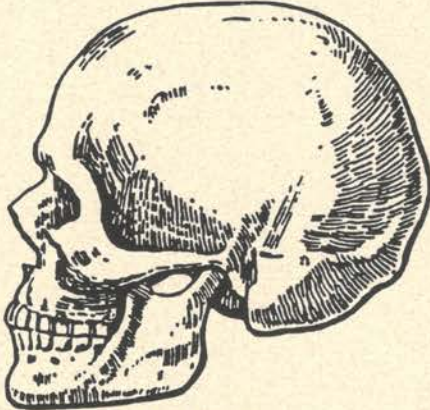

DARWIN

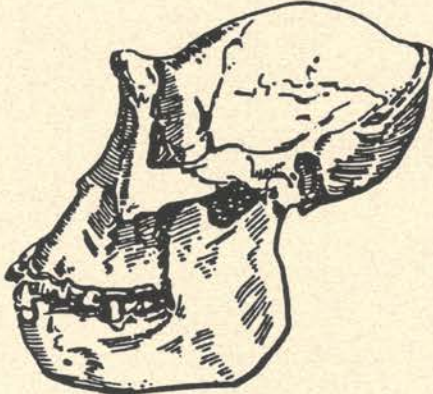

DARWIN

Accept The Metaphor

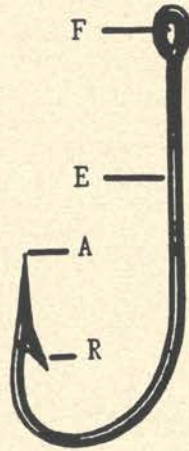

Alphabet Eye

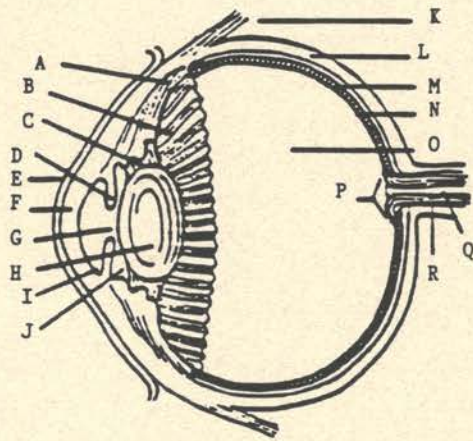

A	-	L
B	-	I
C	-	T
D	-	E
E	-	R
F	-	A
G	-	T
H	-	U
I	-	R
J	-	E
K	-	I
L	-	S
M	-	A
N	-	D
O	-	E
P	-	C
Q	-	O
R	-	Y

The Shape of Religion



F. Frustum
of a cone

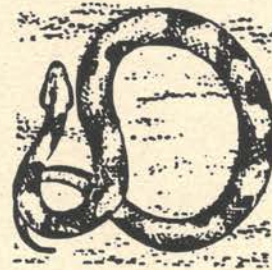

Copperhead
(Length to 3 ft.)

MY GOD IS DEAD CAN I TRY YOURS?

Lifesaver

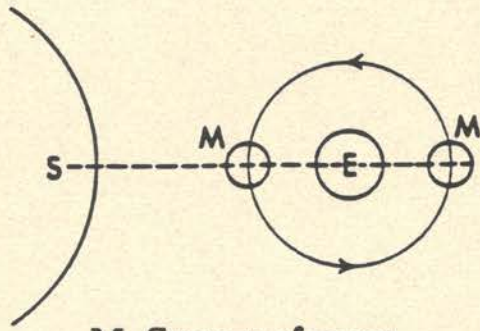

M, Syzygy of moon
S, Sun; E, Earth

life·sav·er



Gas mask

Language Is Everything, Everything Is Language



VERB



NOUN



ADJECTIVE



ADVERB

Lifesaver

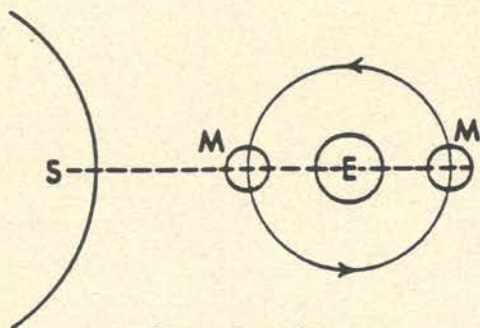

M, Syzygy of moon
S, Sun; E, Earth

life·sav·er



Gas mask

Language Is Everything, Everything Is Language



VERB



NOUN



ADJECTIVE



ADVERB

Ecological Architecture

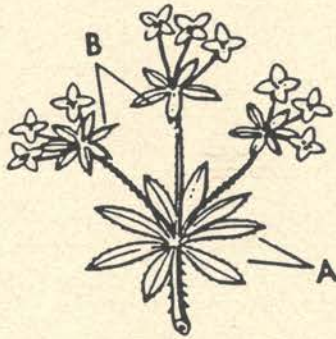

SPLIT LEVEL

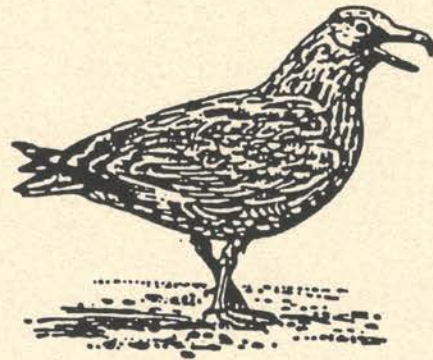

SKYSCRAPER



HIGH RISE



LOW RISE

The General Knowledge of Idiots

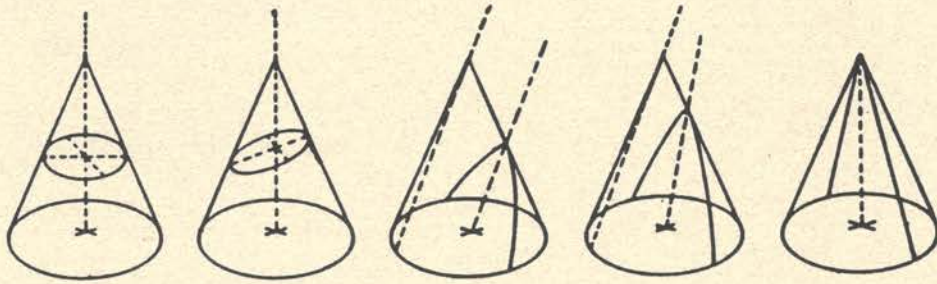

D

N

C

E

HAT