

have you been DUCHAMP'd?
Parts 1, 2, and 3



W. Mark Sutherland

© 1989 The Portable Gallery



**have you been DUCHAMP 'd?
Part 1**

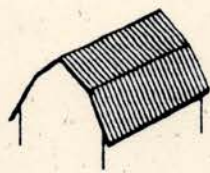

W. Mark Sutherland

I

And why Duchamp? Natural transition of course,
Titles are important, so are instructions for the
the ordering of relics, a place where Freud's
dismantling and re-assembly of co-existing
cancerous tongue is treated like a talisman
contradictions. Poetry grows old and dies
or the bone of a saint. Unknown and ignored
just like people do, it is the art of masturbation
sympiosis or an example of meta-matics?
and the eye of an interior decorator. Think about
And what of Apollinaire? What kind of autopsy
the way we breathe. think about some banal
is to be conducted on his corpse? Who has walked
family occasion in a public park - apocryphal
thru the labyrinth of cubism and emerged
terrorism with respect to the tradition of high
unscathed? The myth of Duchamp, honest
art. The freedom of an unfettered imagination
inconsistency and contradiction is attacked by
is found in the message and the style of delivery.

Y

a breeding culture of absolute indifference.
A few footnotes in fine print won't make any
Transition is cryptic and polyhedral - the first
difference (note: Duchamp = Zen). It is like
thing I do in the morning is breathe! Each day
determining the length of the American coast
I repeat this gesture (repeat this gesture)
line using a piece of string. Important instructions
though it doesn't make any sense and my finely
to follow... be a disciple or a collaborator
calibrated solitude is always searching for a
not a commentator! (Illustration of iconographic
seductive verb as my swollen retina activates
tradition needed). Have you been Duchamp'd? I,
the imagination to the Nth degree. Weak
myself, am Duchamp, an allegory of forgetfulness,
energies, like the heat left by a body on a
a construction in quicksand, neurasthenia, the
chair, a yawn, or a fascinate my
odour of sperm, a vegetable molecule of yeast,

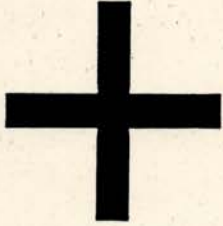

brain and tingle my texticles. Nothing is
a world of desire and unnecessary labour,
is contaminated by physiology or psychological
paralogistic states of co-existence... a
explanations. I, you, me, are a one wo/man
speculative yawn. Words and images are
diaspora, buzzing or spinning around like a fly
termites trapped in a corrupt society - eating
gone mad. Possess/possessions... ossified
enigmas, exposing new dictionaries, exploding
houses made of sand and gauze replace
myths (Cage + Duchamp = ?). Here is a modest
mystified forms of human potential. And
proposal of yoked contradiction creating
the terror continues, unabated - people are
illuminations, philosophical synthesis,
still shot in the streets and kidnappings
complex thought, little epiphanies,
occur without warning, The execution of an
parallel dream polarities, and hallucinations.



idea is left unfinished. Where are the
The locus of your house and hair is in for
instructions for this book and what is the
an angry shake up. Can conversational
difference between poetry and toothpaste,
terrorism be nominated or presented
shaving cream and the colour of iodine.
as a work of art? poetry? music? film?
Previous photographs and poems are not
If you are developing an unsightly tick
certifiable proof of perception. Duchamp
or are on the verge of a nervous
is not a house or a car, he is not a banality
breakdown... try to stay calm,
or an alphabetic filter. He is a transfusion,
take up landscape painting -
an operation to correct your lazy eye,
the condition of a spectator
an image, a gesture, a word.
lasts forever.

||

?

0

**have you been DUCHAMP 'd?
Part 2**



W. Mark Sutherland

VERSION OR VISION?

CLOSED circle

F

a

M

one plastic

modern

another literary

Masquerade

of Myths
TRANSposition of MEANS and sighs + the

and the third
jerk of the second hand on an electric clock

principal

points

of



sh

a

three

DIS=PLACEMENT

knowledge

chANGEable rEALity

demension

body

is

remembered

memory

HO

RIZON

transparency

appearance

T

(the limit

of our gaze)

erOtic desire

apparition

(synonym)

the

H

and

F

E

mailbox contains

an

alphabet or could it be

her brain

L

G

A

R

W

A

ONTOLOGY

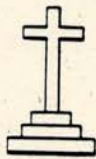

SELF DESIRE

SELF

V

I



raft

T

raw material is a breeding ground of dust
the copy of a copy of an idea a spinal column

another strange property interrupted ()

O

Y

S

N

C

I

H AD

I

T

E

L

A

L

DE-formed I ron Y?

\$% ^ & * # @ % 3

under

taker

a system of mirrors that

plastic

change directions

composition

(I love these cracks)

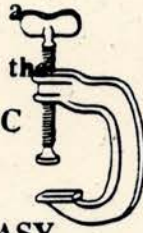

empty

moment

d/n

ull

SEPERATE AC
IT IS

DIFFERENCE

= SIMILARITY

NOT EASY

TO JUGGLE

WITH

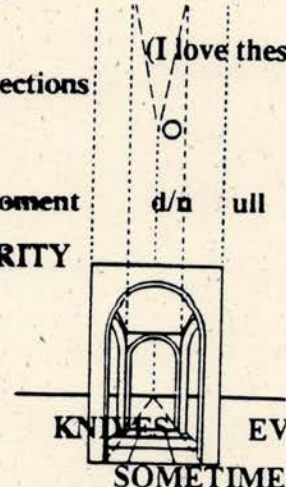

KNIVES

EVEN

SOMETIMES

bride = glass

decompose

attitude

metaphysical

gesture - X ray

dust

no piano

shadow

latitude

4

+ reality brainfact cigars bachelor house

car window cage under wood objects subject

META

WOR(L)D

chocolate

1/2

wo/man made

ShIfT

cOnTeXt

----- enviromental installation

network of puns

ironic machine

philologist

incomplete

enigma

tromp-l'oeil

glass

ready

morphology

g ass

schematic

stupid as a poet

lass

widow

gasin

bicycle

ass

gas/in

as

ga/sin

gla

la

a

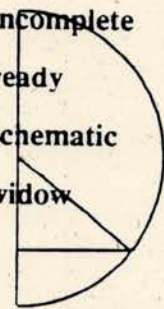

wasted energies ----- forbidden glance

a forest hides the skin behind your ears

RED w hich way do ink tim e mise rable

c/h ell invented the circle ICONOC

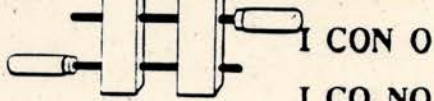

I CON O

I CO NO

ICO NO

TASTE = repetition

lllllllllaaaaaaaaazzzzzzzzyyyyyyyyyyy

kkkkkkkssssssssss

the growth of hair

wh y BECAUSE

LAST IC

CLAS TIC

LA ST IC

LA STIC

not ruled by time and space

tttttttttrrrrrrrraaaaaaaacccccccccckkkk

fainting

sneezing

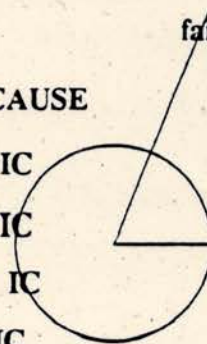

the fly stops

when

(a cunning array of stunts)

buzzing

nobody listens

versus domestic licks)

1 eye open

G rammar

MoDuLaTiOn

2 eyes open

+

ear -----moving

inscriptions ----- mess age

strain identify

im age

train recognize

p age

rain similar

objects from the memory imprint

and

conditions of language

necessary possibilities / contrary directions

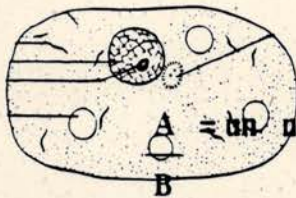

the vertical axisi of practical value

+ residue of experience

NOTHING PERHAPS

PLANS

(FREQUENCY OF POETRY) ----- see/look the limb of the heart

volumes of electricity h eat, umorsav agingfraud

re - form

reform

forgo

con text

discipline pro verb

ego

RAT IONAL JUST I FICTION

dead ()nd

d ad e

= breathe

rhythmes =

where is your left



industrial rust



FRAGMENT

semiotics

versus

mimesis

the body of language eludes/alludes stuterrrrrrrrriiiiiinnngggg ffffaaaarrrrrrtttttssss
finger sign animal

ches s/t

rain

a to z

p

X

X

typing errors

verisimilitude

important errors heavy with compassion

cell cell

sounds

music

right

tired

to

is

these

sound

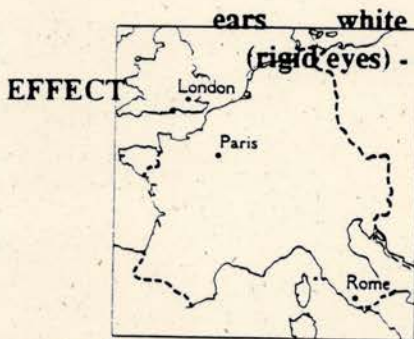

EFFECT

blind wo/man

words

are

stones

(not to be repeated)

voca l

bu ary

(rather than working

from meta phor) a n t

lie a ing

REAL

OSCILLATING TIME vibrates..... ir/relevance

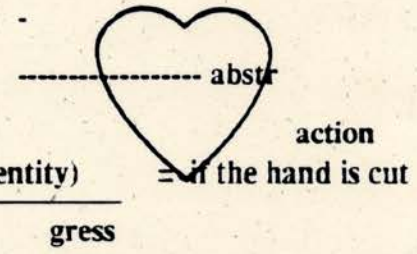
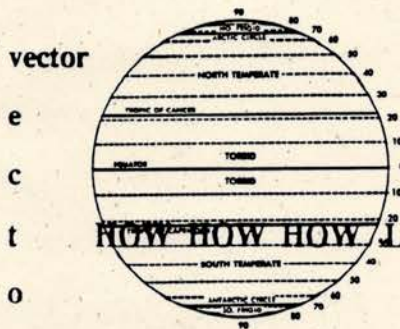

t i red of fried fish and cockroaches - - - - -

shoes C
 avocados A
 toilet paper R
 single cigarettes D S(N)O UN(D)S under stand ing
 typed letter B i(n) form ation

O
 A
 R --.9 there is always a smile hovering
 D at the corner of your mouth

the greater the order the greater the chaos the greater the chaos
 the greater the order the greater the chaos the greater the chaos
 the greater the order the greater the chaos the greater the chaos

S/HE CUT THEIR FINGER IN SURGERY

sex

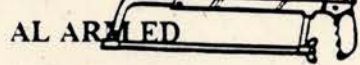

AL ARMED

ir/resistible

(K/H ISS)

in exhaustable

kaleidoscope

re

S/WORD

=

(all

armed)

DE

(hOaX)
 hardened consumer
 A(le)RT
 VICES
 (SnEEr)

assembly

PARTICLES

(universe)

in

determinate

A

per

mutations

R

T

dominate

I

THEIR TOMB IS A TRASH CAN.....



TECHNOLOGY

C

(corkscrew)

L

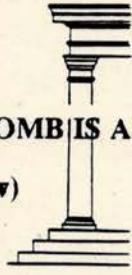

THE beauty of

in

DIFFERENCE

method

E

(thanks for the anecdote)

S

principle pun

pun principle

mental

surgery

FINALLY

UN

finished

invent

-

transcend

urgency

=

our next door neighbor

the imminence of the present moment belongs

to all centuries caught by the vertigo of

DDDDDDDDDDDEEEEEEEEEEEEEELLLLLLLLLLAAAAAAAAAAAAAAAAAYYYYYYYYYYYY

ULTRARAPID EXPOSURE

ULTRARAPID EXPOSURE

ULTRARAPID EXPOSURE

ULTRARAPID EXPOSURE

ULTRARAPID EXPOSURE

ULTRARAPID EXPOSURE

ULTRARAPID EXPOSURE

ULTRARAPID EXPOSURE

ULTRARAPID EXPOSURE

ULTRARAPIDEXPOSURE

prophecies

of a

mutation

a

shadow

an

object

an

idea



SUBJECT?

homonyms

a delirium of wor(l)ds

MULTIPLE ID ENTITIES _____

(recuperates meaning)

to

NOT/LESS



FIXED

and

SEEN

SPECTATOR

from

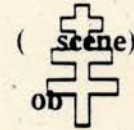

universalreversaluniversalreversaluniversalreversaluniversalreversaluniversalreversaluniversalreversaluniversalreversal
reversaluniversalreversaluniversalreversaluniversalreversaluniversalreversaluniversalreversaluniversalreversal

begin

game

(5 seconds)

end

game

l east

retain

per verse

nex us

abandon

RE

SOLUTION

apprehend

all objects are =

+ real contra diction

pre end

t

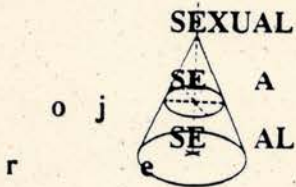

BIN OCULAR VISION

(GESTURE)

PSYCHOANALYSIS



VICE

i

o

n

3 or 4 drops of rain on the edge of sleep

tion

s p
i e
l c
e r
n e
t p

PARADOX.....

.....PARADOX

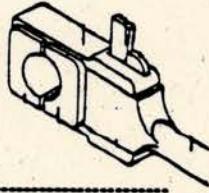

PARADOX.....

.....PARADOX

AFTER -

speed (seed)

operating instructions

is

r evolution

IMAGE

frozen

vocabulary

a painted shadow (traces of being)
FALSE

voca l
or point of no return

FASCILE

undress/regressFO

SIL..... fix the idea

tomorrow I will go to the museum

to pray for your wounded eyes U

N

F

I

N

I

S

H

E (a)

D



incomplete

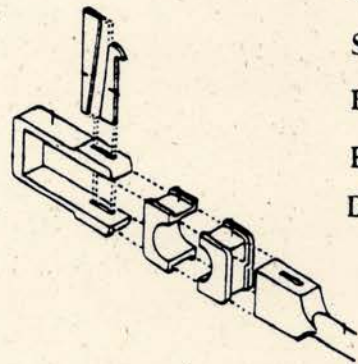

**have you been DUCHAMP 'd?
Part 3**

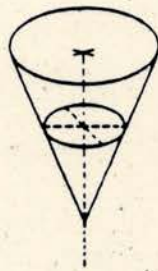

W. Mark Sutherland

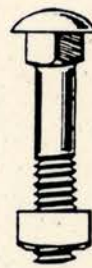
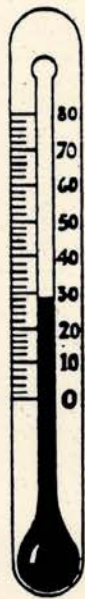

ab-sence

in the work of removal.

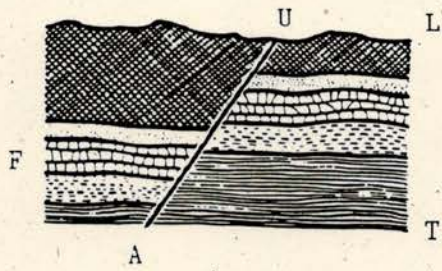

be
near the mouth

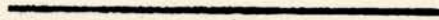

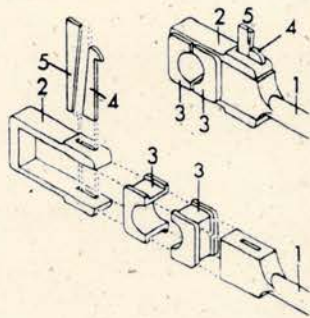

Optic nerve

S	A	T	E	D
A	T	O	N	E
T	O	A	S	T
E	N	S	U	E
D	E	T	E	R

Retinal artery

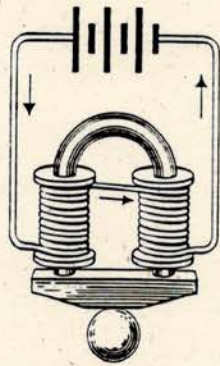

Y

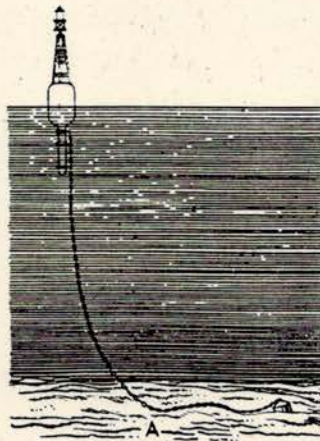

Blind spot

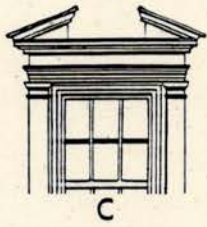

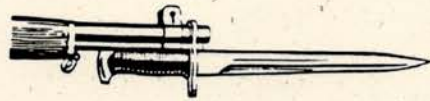

sions of loud expres-



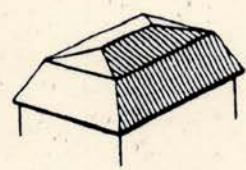
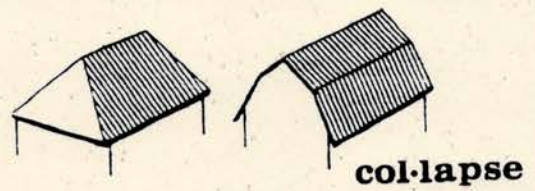
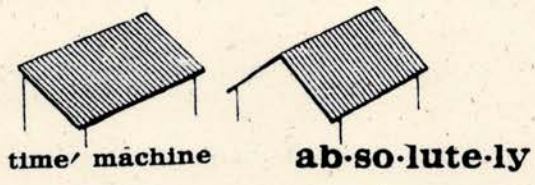

explod/ed view

columns

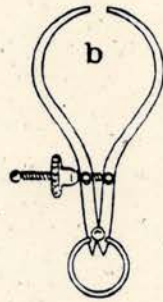

end

A

p

art

t



he

room

the rough

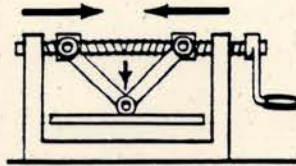

b eating

B locks

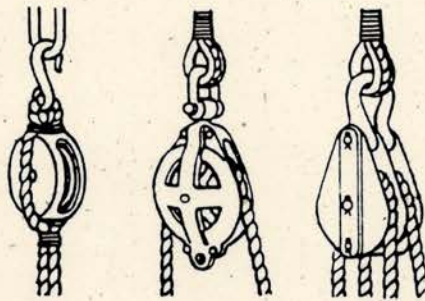

beheaded.

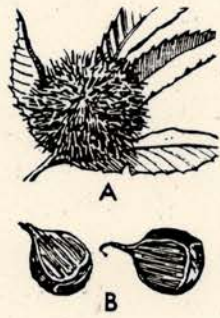

rising ground. Also.



cohesion.





fault



knot²

breathe out =
ex·pi·ry
of breath.
ex·plain
intelligible
something:

SEE LETTER U

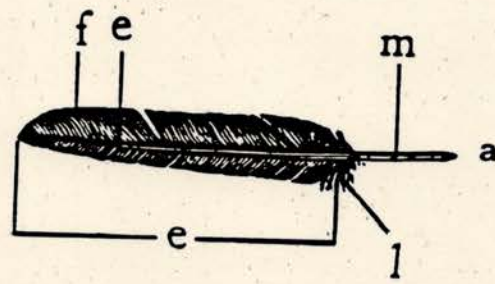
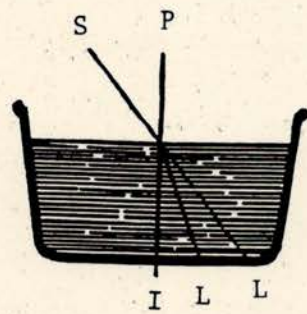

pee per

Prolonge knot



a period of time within which an action or procedure must be done or completed.

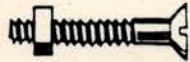

all

co-her-ence
stick

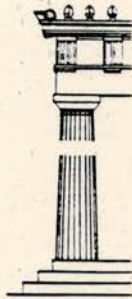

released

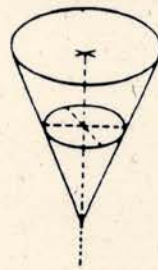

smoke

